



LIEBIG ULTRAPLUS

The undercut anchor for exceptionally high loads in cracked and non-cracked concrete

Bringing it together.

LIEBIG ULTRAPLUS M12 – M36

Unique technology, unrivalled performance

Since 1946, LIEBIG's unique anchoring technology has become synonymous around the world for providing reliable solutions to achieve the highest performance levels in safety-critical applications. And since 2017, the LIEBIG brand has been part of the EJOT Group's portfolio of concrete anchoring products.

Without doubt, the LIEBIG ULTRAPLUS undercut anchor is regarded as the brand's flagship product. With unparalleled high load performance to work with, designers can aim much higher and consider a wider range of potential applications when compared to regular undercut anchors. This is why ULTRAPLUS has become the undercut anchor of choice in so many ultra-high performance industry applications worldwide.

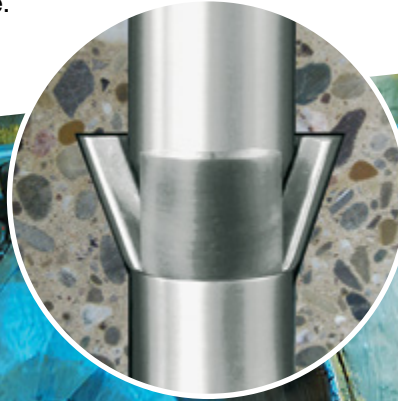
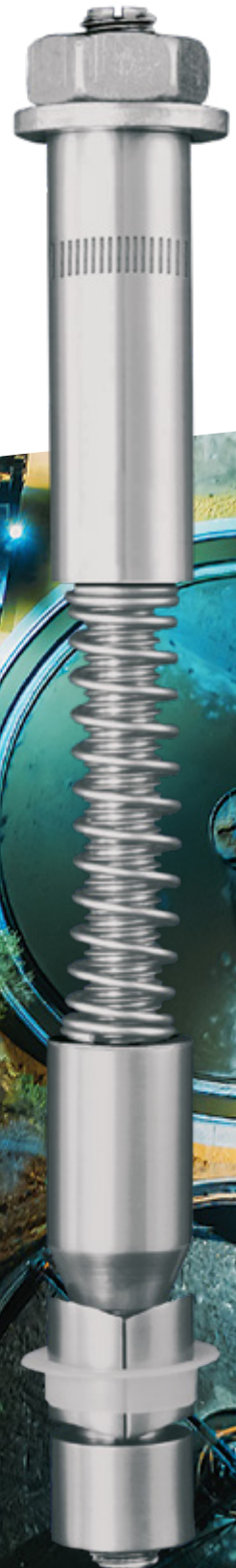

LIEBIG ULTRAPLUS M12 – M36

Unique technology, unrivalled performance - introduction

Page 2

Contents



Engineered for exceptionally high loads in cracked and non-cracked concrete

Performance benefits and characteristics [Pages 4-5](#)
 Standard lengths and diameters [Page 5](#)
 Option One Approval [Page 5](#)



The only undercut anchor that works just like cast-in

The ULTRAPLUS principle [Page 6](#)
 Modularity and bespoke solutions [Page 7](#)



Installation guidance

ULTRAPLUS and accessories [Page 8](#)
 Installation instructions [Page 9](#)



Technical data

Permissible tension and shear loads [Page 10](#)
 Permissible bending moments [Page 10](#)
 Spacings, edge distances and member thicknesses [Page 10](#)



Support offsite, onsite and online

Calculation software [Page 11](#)
 Site testing [Page 11](#)
 Websites and verification [Page 11](#)

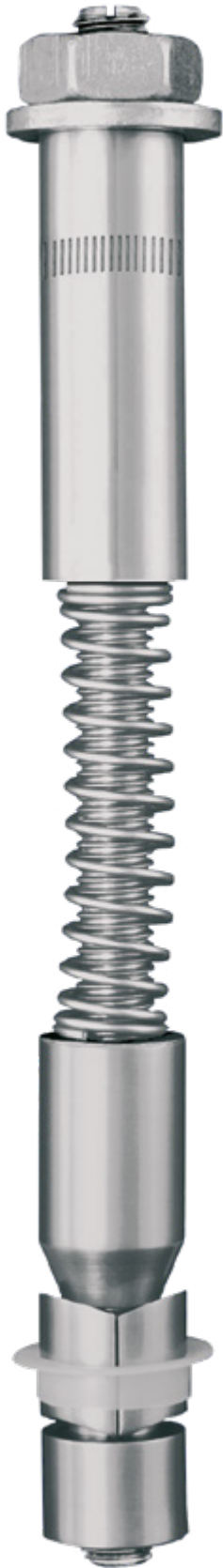

Engineered for exceptionally high loads in cracked and non-cracked concrete

The LIEBIG ULTRAPLUS is engineered to resist very high loads in both tension and shear, delivering a level of operational safety that is unrivalled. Its unique reverse undercutting mechanism makes it the only undercut anchor available to the market that performs like a cast-in anchor to offer a unique post-installation alternative.

LIEBIG ULTRAPLUS is therefore a perfect fit for applications where absolute reliability is essential. Numerous projects globally verify these credentials and include nuclear power plants, industrial plants, conveyor systems, cranes, as well as special civil engineering solutions.

Performance Benefits and Characteristics

- Unique undercut in the direction of load - offering significant stress reduction within the concrete
- Positive undercut with strong mechanical interlock
- High margin of safety due to positive undercutting
- Unique spring activated anchor:
 - Automatically compensates for tolerances in the fixture thickness
 - Instant and automatic engagement with the undercut within the concrete
- Comparable performance to a cast-in headed stud
- Instant loading
- Completely removable
- Through-fix installation
- Zero expansion forces
- Reduced edge distances and anchor spacings
- Proven performance for dynamic loads, shock loads and seismic conditions

Standard lengths and diameters

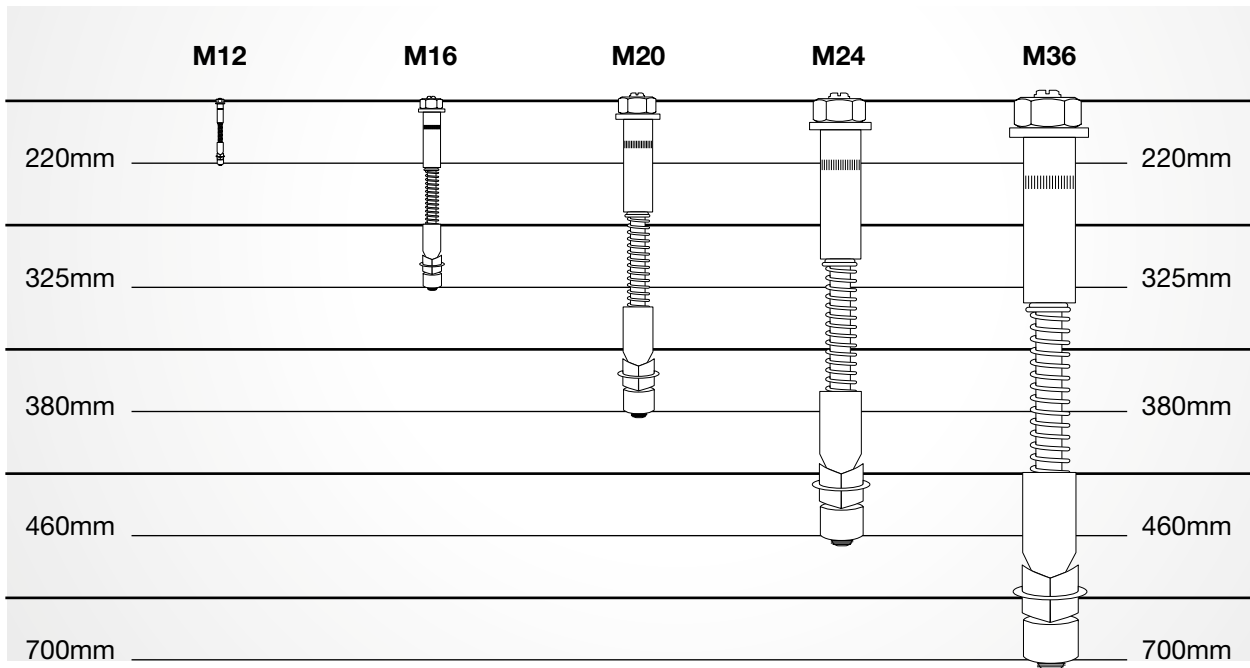

Custom lengths available

Product Material

- Produced from high strength carbon steel grade 10.9
- Stainless steel grade A4/80

Product Range

- M12 – M36, carbon steel, zinc plated, HDG, sherardized, stainless steel
- Custom lengths and assemblies readily available

Base Material

- Engineered specifically for use in cracked and non-cracked concrete

Load Range

- Extremely high tensile and shear capacity
- Tension: $N_{perm} = 19.0 - 320.2$ [kN]
- Shear: $V_{perm} = 45.2 - 371.4$ [kN]
- Higher loads are achievable by increasing material properties and component dimensions. Please contact our technical support services for more information.

Typical Application Area

- Designed for high-load safety critical applications:
 - Nuclear power plants
 - Water treatment plants
 - Steel construction
 - Industrial plants
 - Petrochemical installations
 - Cranes
 - Civil engineering projects (bridges etc)
- Expert reports available for Shock and ACI 355 compliance.

Approval

- ETA-04/0098 – Option 1 – Approved for cracked and non-cracked concrete
- Independent verification according to ACI 355



European technical approval option1

The only undercut anchor that works just like cast-in

How the Ultraplus principle works

When the anchor is installed, the expansion segments are expanded into the previously created undercut. The pretensioned spring releases the segments into the undercut void. Engagement is indicated by a distinctive and audible 'click'.

This results in a "positive undercut" connection with unique keying in the direction of load, without any expansion forces being transferred into the concrete.

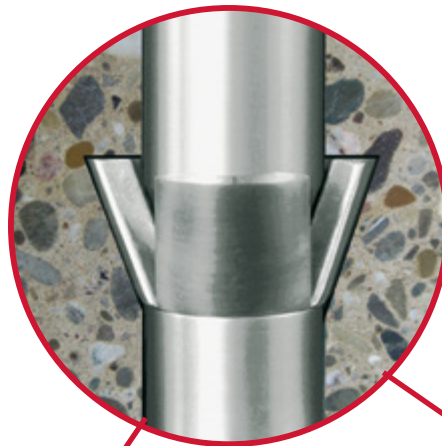

Expanding segments

Automatic release with an audible 'click' on expanding into the undercut void



Plastic security ring

Holds the segments together and remains within the fixture both on the face and inside the clearance hole

Undercut / cast-in comparison

These diagrams illustrate how the ULTRAPLUS principle mirrors the reaction forces of a cast-in anchor in concrete.

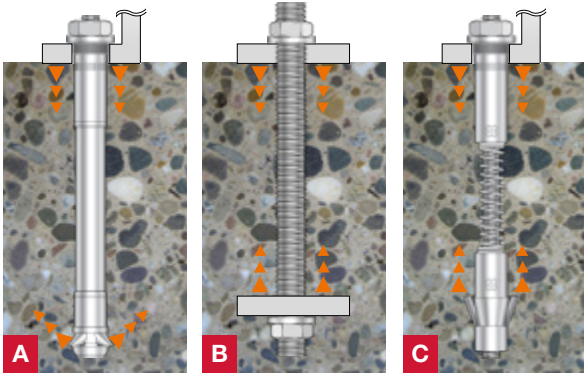

A. Normal undercut anchor

Compression of the concrete is created by partial expansion forces being created at the bottom of the anchor.

B. Typical cast-in place anchor

Compression of the concrete is achieved between the cast-in washer plate and the concrete.

C. LIEBIG ULTRAPLUS anchor

Compression of the concrete is achieved between the undercut and the concrete surface.

Pretensioned spring

Provides constant pressure and expands the undercut segments during installation

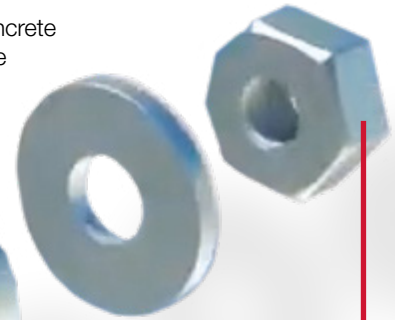

Larger diameter nut and washer

Providing greater distribution of the clamping force on to the item to be fastened.

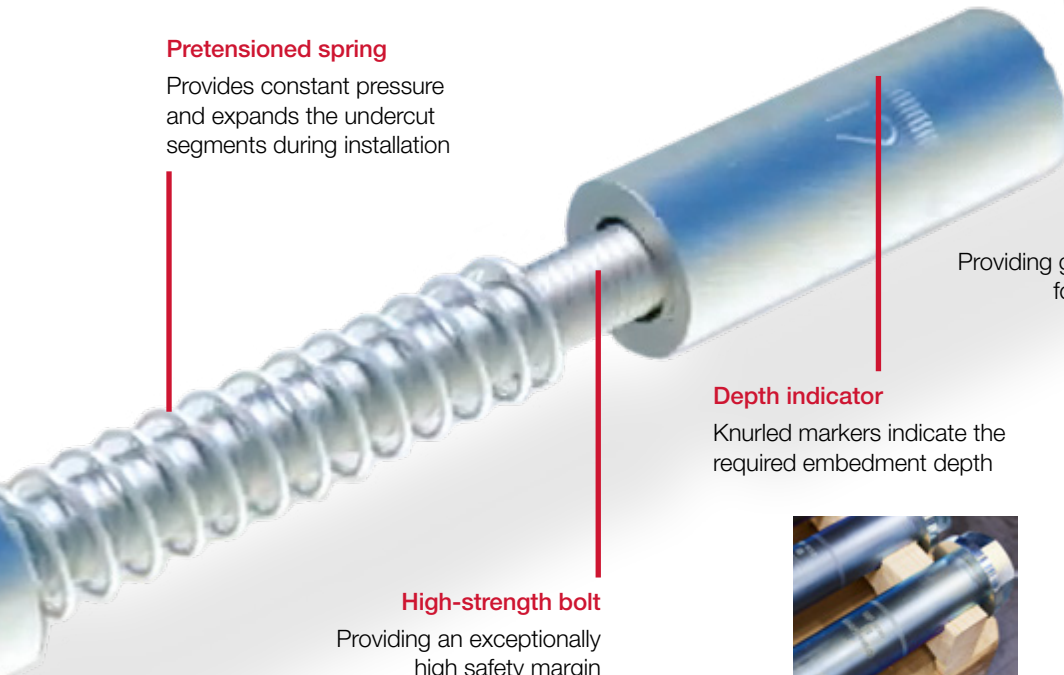

Depth indicator

Knurled markers indicate the required embedment depth

High-strength bolt

Providing an exceptionally high safety margin

Modularity means that customised solutions are easily achievable

The modular design of ULTRAPLUS adds to its specification versatility because bespoke lengths of the main components can be manufactured by EJOT with ease and without significantly adding to cost and lead times.

In reality, very few applications are genuinely standard. The ULTRAPLUS concept is highly configurable to specific requirements, rather than expecting the application to be designed to suit the anchor's own characteristics.



ULTRAPLUS M12 - M36

Installation guide and accessories

ULTRAPLUS Carbon Steel Zinc Plated

Threaded stud with hex nut and washer.

Available in high strength zinc plated, sherardized, HDG and stainless steel.

Approval: ETA-04/0098 – Option 1 for cracked and non-cracked concrete.

ALSO AVAILABLE IN OTHER MATERIALS

Custom sizes available

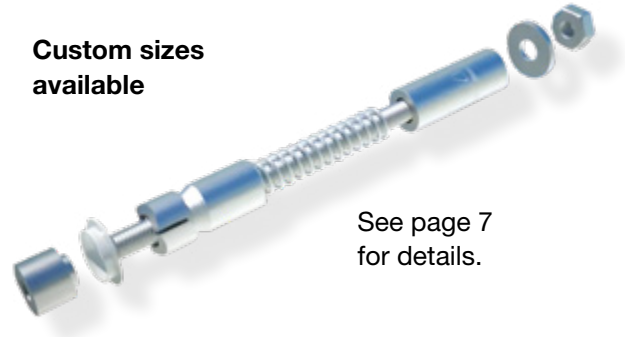

See page 7 for details.

Type	Order Code	Thread Size	Diameter x Depth of Drilled Hole	Max Fixture Thickness	Fixture Hole Diameter	Eff. Embedment Depth	Total Length	Weight (kg/100pcs)	Box Quantity
UP M12-23/140/20	UP1223140020	M12	23x190	20	24	140	220	48	10
UP M16-30/220/30	UP1630220030	M16	30x300	30	32	220	325	123	5
UP M20-36/250/50	UP2036250050	M20	36x330	50	38	250	380	173	5
UP M24-45/280/60*	UP2445280060	M24	45x410	60	46	280	460	408	2
UP M36-67/420/100*	UP3667420100	M36	67x570	100	68	420	700	1305	1

Also available in HDG, sherardised and stainless steel. *Not included in approval. Custom lengths available on request.

Undercutting tool for core drilling rigs with 1/2" drive

Compatible ULTRAPLUS	Order Code
M12	D23
M16	D30
M20	D36
M24	D45
M36	D67



Undercutting tool is available for either purchase or hire.

Diamond cutting blade

Compatible ULTRAPLUS	Order Code
M12	DE23
M16	DE30
M20	DE36
M24	DE45
M36	DE67



Installation data

Thread Size			M12	M16	M20	M24	M36
Drill hole diameter	d_0	[mm]	23	30	36	45	67
Drill hole depth	h_1	[mm]	190	300	330	410	570
Diameter of undercutting	d_1	[mm]	35	47	53.5	74	105
Undercutting	Δd_{cut}	[mm]	6	8.5	8.75	14.5	19
Clearance hole in the fixture	Through-fix anchorage	d_i	24	32	38	46	68
	Installation on threaded stud	d_i	14	18	22	26	39
Width across flats	sw	[mm]	24	36	41	50	75
Installation torque	T_{inst}	[Nm]	120 (80 Stainless Steel)	250	300	790	2000

Installation instructions

1 Drill hole.

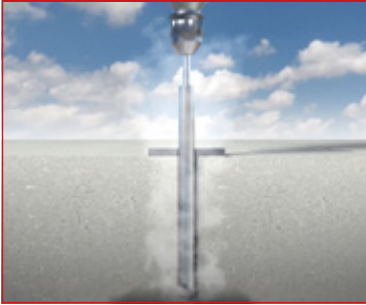

2 Clean hole with a blow pump.



3 Create the undercut using LIEBIG undercutting tool (approximately 15 to 70 seconds depending on the anchor size). Irrigate with water while undercutting.



4 Install the LIEBIG ULTRAPLUS undercut anchor. The plastic ring holding the undercutting segments together will remain at the fixture.



5 Apply the specified installation torque using a calibrated torque wrench – the ULTRAPLUS undercut anchor is now installed and can resist loads immediately!



Installed anchor

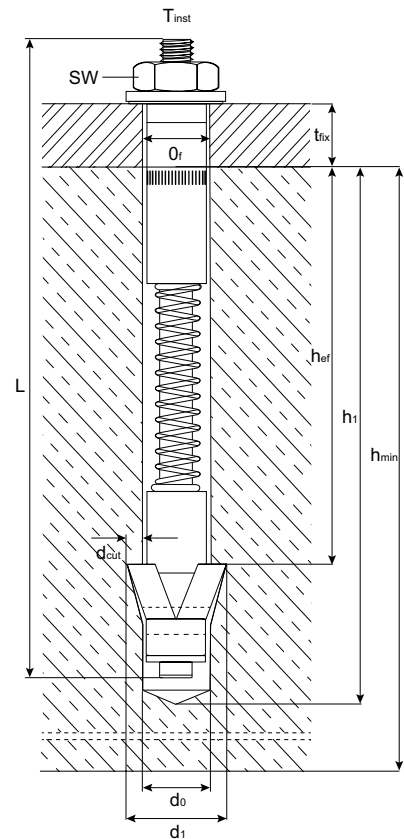

Installation video now available on the EJOT UK YouTube channel

Permissible tension loads¹⁾ - Carbon Steel Zinc Plated (Stainless Steel A4)

N_{perm}	Cracked Concrete	C20/25	[kN]	19.0 (19.0)	35.7 (35.7)	45.2 (45.2)	80.3 (80.3)	147.6 (147.6)
		C30/37	[kN]	23.2 (23.2)	43.6 (43.6)	55.2 (55.2)	98.0 (98.0)	180.0 (180.0)
		C40/50	[kN]	26.9 (26.9)	50.4 (50.4)	63.8 (63.8)	113.3 (113.3)	208.1 (208.1)
		C50/60	[kN]	30.1 (29.9)	56.4 (56.3)	71.5 (71.5)	124.5 (124.5)	228.7 (228.7)
	Non-Cracked Concrete ³⁾	C20/25	[kN]	28.6 (28.6)	45.2 (45.2)	66.7 (66.7)	111.9 (111.9)	206.6 (206.6)
		C30/37	[kN]	34.9 (29.9)	55.2 (55.2)	81.3 (81.3)	136.5 (126.1)	252.0 (252.0)
		C40/50	[kN]	40.3 (29.9)	63.8 (56.3)	94.0 (87.5)	157.8 (126.1)	291.3 (291.8)
		C50/60	[kN]	43.4 (29.9)	71.5 (56.3)	105.3 (87.5)	173.5 (126.1)	320.2 (291.8)

Permissible shear loads^{1) 2)} - Carbon Steel Zinc Plated (Stainless Steel A4)

V_{perm}	Cracked Concrete	C20/25	[kN]	45.2 (48.3)	81.0 (85.9)	109.5 (123.5)	160.6 (160.6)	295.1 (295.1)
		C30/37	[kN]	45.2 (48.3)	81.0 (85.9)	109.5 (123.5)	164.6 (196.0)	360.0 (360.0)
		C40/50	[kN]	45.2 (48.3)	81.0 (85.9)	109.5 (123.5)	164.6 (196.0)	378.6 (416.1)
		C50/60	[kN]	45.2 (48.3)	81.0 (85.9)	109.5 (123.5)	164.6 (196.0)	378.6 (445.5)
	Non-Cracked Concrete ³⁾	C20/25	[kN]	45.2 (48.3)	81.0 (85.9)	109.5 (123.5)	164.6 (196.0)	378.6 (414.0)
		C30/37	[kN]	45.2 (48.3)	81.0 (85.9)	109.5 (123.5)	164.6 (196.0)	378.6 (445.8)
		C40/50	[kN]	45.2 (48.3)	81.0 (85.9)	109.5 (123.5)	164.6 (196.0)	378.6 (445.8)
		C50/60	[kN]	45.2 (48.3)	81.0 (85.9)	109.5 (123.5)	164.6 (196.0)	378.6 (445.8)

Permissible bending moments^{1) 5)} - Carbon Steel Zinc Plated (Stainless Steel A4)

M_{perm}	[Nm]	62.4 (56.4)	158.1 (142.9)	309.0 (278.7)	534.5 (481.1)	1881.7 (1693.5)
------------	------	-------------	---------------	---------------	---------------	-----------------

Spacings, edge distances and member thicknesses

Effective embedment depth	h_{ef}	[mm]	140	220	250	280	420
Characteristic spacing ⁴⁾	$s_{cr,N}$	[mm]	420	660	750	840	1260
Minimum spacing	s_{min}	[mm]	140	220	250	280	420
Characteristic edge distance ⁴⁾	$c_{cr,N}$	[mm]	210	330	375	420	630
Minimum edge distance	c_{min}	[mm]	140	220	250	280	420
Minimum member thickness	h_{min}	[mm]	240	360	400	500	700
			-	330 ⁶⁾	360 ⁶⁾	-	-

1) The permissible loads have been calculated using the partial safety factors for resistances stated in the ETA-approval and a partial safety factor for actions of $\gamma_F = 1.4$.

The permissible loads are valid for unreinforced concrete and reinforced concrete with a rebar spacing $s \geq 15$ cm and reinforced concrete with a rebar spacing $s \geq 10$ cm if the rebar is 10 mm or smaller.

2) The permissible shear loads are based on a single anchor without influencing concrete edges. For shear loads applied close to an edge ($c \leq 10 h_{ef}$ or $60 d$) concrete edge failure must be checked per ETAG 001, Annex C, design method A.

3) Concrete is considered non-cracked when the tensile stress within the concrete is $\sigma_L + \sigma_R \leq 0$. In the absence of detailed verification $\sigma_R = 3$ N/mm² can be assumed (σ_L equals the tensile stress within the concrete as a result of external loads, forces on anchors included).

4) If spacings or edge distances become smaller than the characteristic values (i.e. $s \leq s_{cr,N}$ and/or $c \leq c_{cr,N}$) a calculation per ETAG 001, Annex C, design method A must be performed. For details, see ETA-04/0098.

5) The permissible bending moments are only valid for the threaded stud (e.g. in case of a distance mounting).

6) This h_{min} only applies when the remote face of the concrete is inspected to ensure there has been no break-through as a result of drilling. Otherwise $h_{min} = 360$ mm (M16) and $h_{min} = 400$ mm (M20).



Calculation software

EJOT's Anchor-fix dimensioning software is a 'go-to' tool to assist designers with pre-planning through to static requirements for critical building projects.

The program was developed for structural engineers, specifiers, engineers and technicians to calculate the load-carrying capacity of anchor bolts in concrete substrates - allowing data to be archived for reference.

Download here:

www.ejot.co.uk/software-anchorfix



On-site testing and support

When specifying outside of any standard technical parameters our technical team will recommend an on-site test report, carried out by a qualified EJOT engineer.

No-one can second guess the integrity of substrates. We want our customers to have absolute peace of mind and confidence in the match between fixing and substrate - and the correct installation process. All our field based engineers are CFA approved testers.



Verified by Constructionline

EJOT UK is now verified and approved by the industry-leading procurement and supply chain management service, Constructionline.

LIEBIG online

We offer two online website resources.

www.liebig.co.uk

This website is dedicated uniquely to all current LIEBIG products and presents a fast but comprehensive overview.

www.ejot.co.uk

Our main UK website for all EJOT and LIEBIG products. This site also provides a comprehensive webshop facility.





EJOT U.K. Limited,
Hurricane Close,
Sherburn Enterprise Park,
Sherburn-in-Elmet,
Leeds LS25 6PB.
United Kingdom

Tel: +44 1977 68 70 40

Email: liebig@ejot.co.uk

www.ejot.co.uk

www.liebig.co.uk

Bringing it together.